

EAST ROCKHILL TOWNSHIP
1622 Ridge Road, Perkasie, PA 18944
215-257-9156 fax: 215-257-1299
www.eastrockhilltownship.org
Staff@EastRockhillTownship.org

TO BE SUBMITTED:

- Completed Deck/Patio Application
- Completed Zoning Permit Application
- Zoning Fee
- Construction Drawing
- Plot plan with placement of proposed construction & distances to property lines.
- Two (2) complete sets

WOOD DECK:

- Footings
Include size, depth, height, location and method of installation.
- Framing
Include size, type and spacing of floor joists, show the method of attachment to house, (ledger board, flashing, wood to wood, lag bolts (size and spacing) etc.) Show joist hangers, girders, support posts (size and location). Note: if deck is over six feet (6') above grade, 6x6 posts are required.

Also, include detail of guardrails, which are required if the proposed deck is located more than 30 inches (30") above grade. Guardrails shall not be less than 36 inches (36") in height and shall have intermediate rails or ornamental closures which will not allow passage of an object six inches (6") or more in diameter.

Decks and balconies are required to provide a live load factor of 60 pounds (60 lbs.) per square foot.

PATIO:

- Complete the depth of the slab/fill as well as footing depth, if applicable.

CONCRETE GROUND SLABS

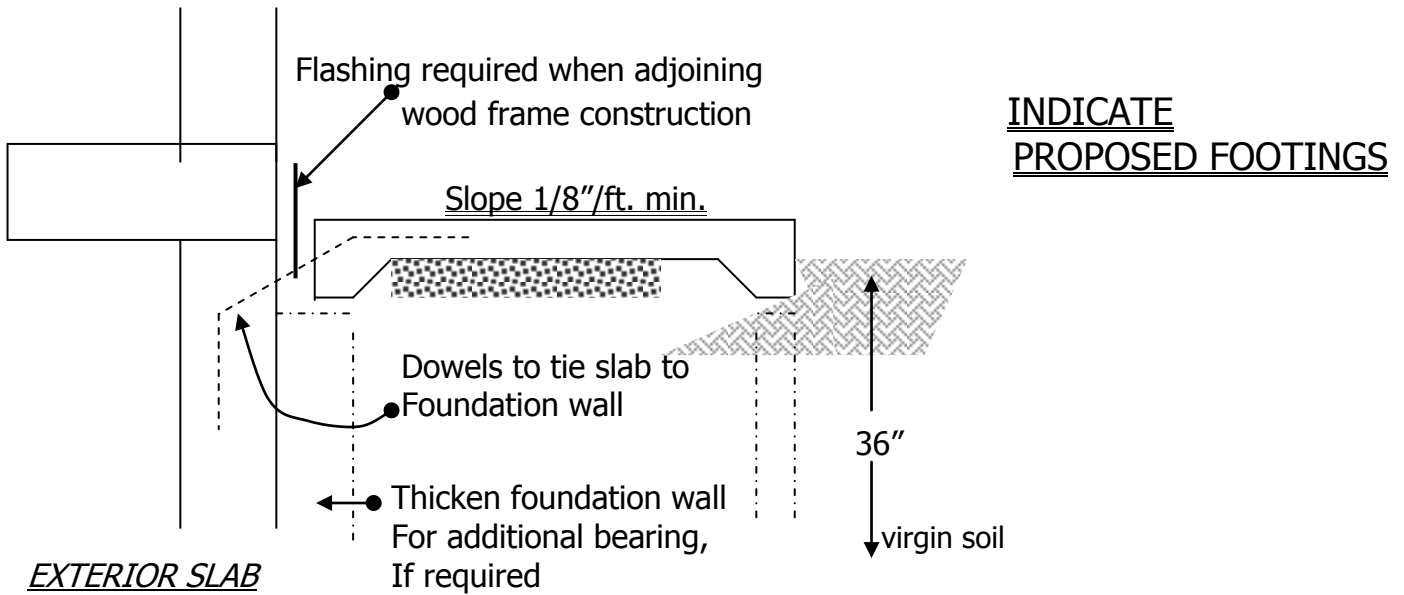
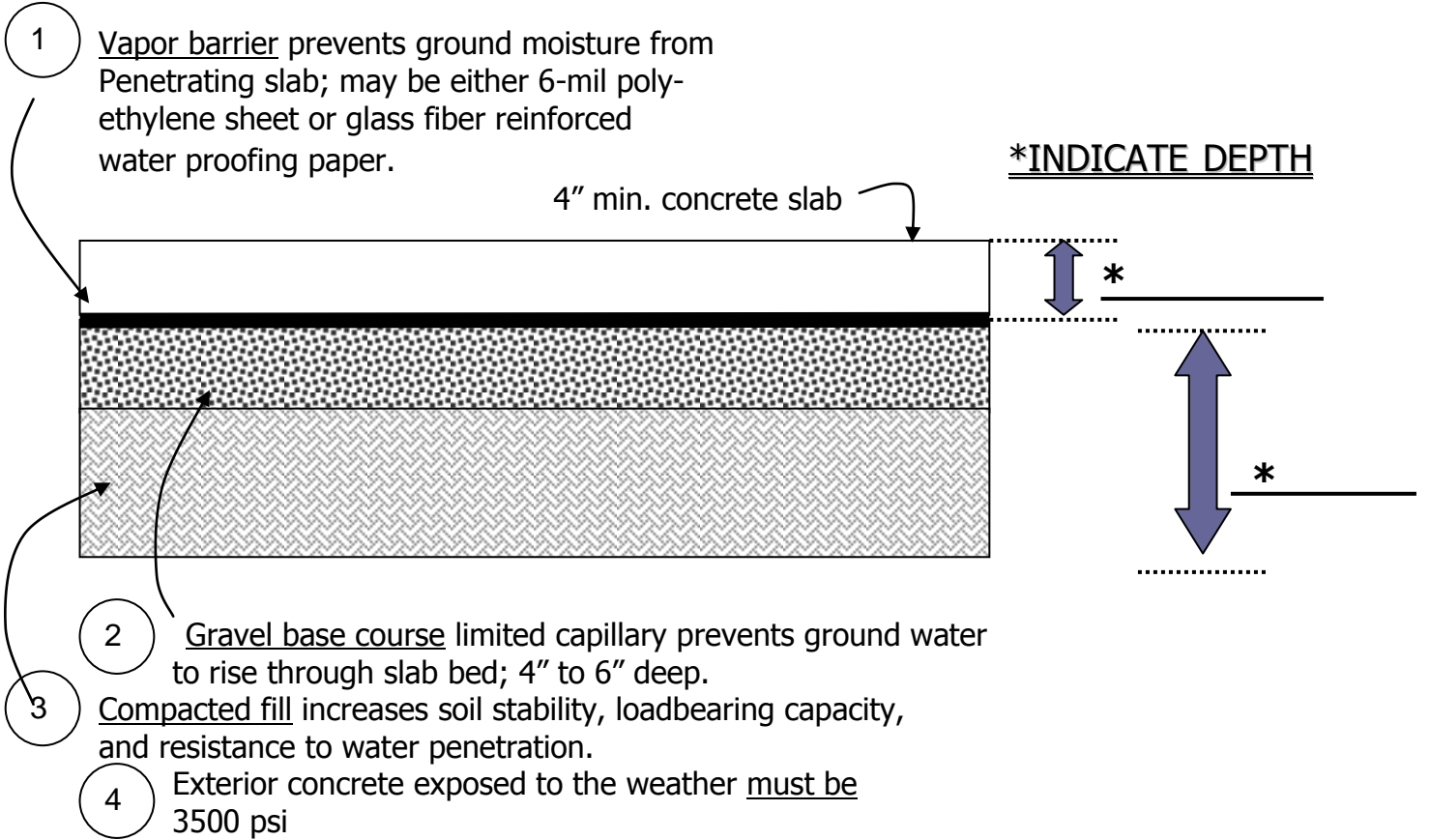

DECK or PATIO APPLICATION

1. PROPERTY INFORMATION

Street Address		Zip	Parcel Number	Zoning
Subdivision	Lot Number	Parcel Type <input type="checkbox"/> Residential (R) <input type="checkbox"/> Industrial (I) <input type="checkbox"/> Commercial (C) <input type="checkbox"/> Other (O)		

2. OWNER INFORMATION

First Name	Last Name or Business Name	Phone		
Street Address		City	State	Zip

3. CONTRACTORS INFORMATION

	NAME OF CONTRACTOR	STREET ADDRESS	CITY, STATE
Applicant (not owner)			
Architect / Engineer			
General Contractor			
Concrete			
Electrical (if any)			

4. DECK/PATIO DESIGN INFORMATION

Construction Drawings & Plot Plan REQUIRED

DIMENSIONS OF DECK/PATIO: _____
 HEIGHT OF DECK/PATIO OFF THE GROUND: _____
 DECK/PATIO: Attached Free-Standing

WOOD DECK INFORMATION:

TYPE OF WOOD: _____
 BEAMS: Under Joists Even with Joists
 POSTS: In-Ground On Piers
 DIRECTION OF DECKING: _____
 BENCHES: _____

TYPE OF DECKING MATERIAL:

Pressure Treated: 5/4 x 6 #1 2 x 6 #1 2 x 6 #2
Cedar: 5/4 x 6 2 x 6
Trex: 5/4 x 6 2 x 6

STAIRS: Placement: _____ Width: _____
 STAIR RAILING: Both Sides Left Side Right Side
 GUARD RAILING: Height: _____
 HAND RAILING: Placement: _____ Height: _____
 TYPE OF RAILING WOOD: Pressure-Treated Cedar Trex
 TYPE OF FASTENERS ON DECKING: Galvanized Nails Stainless Steel Screws/Washers

5. CERTIFICATION

I hereby certify that I am the owner of record of the named property, or that the proposed work is authorized by the owner of record and that I have been authorized by the owner to make this application as his/her authorized agent and I agree to conform to all applicable laws of this jurisdiction. In addition, if a permit for work described in this application is issued, I certify that the code official or the code official's authorized representative shall have the authority to enter areas covered by such permit at any reasonable hour to enforce the provision of the code(s) applicable to such permit.

Signature of Applicant	Address	Phone No.
Homeowner Signature (required)		Phone No.



EAST ROCKHILL TOWNSHIP

1622 Ridge Road, Perkasie, PA
215-257-9156
www.EastRockhillTownship.org

ZONING PERMIT APPLICATION

TAX PARCEL Number: 12-_____

Date: _____

PROPERTY ADDRESS: _____

APPLICANT Name: _____ Phone No.: _____

Address: _____ Fax No.: _____

e-mail: _____

If different than applicant:

OWNER Name: _____ Phone No.: _____

Address: _____ Fax No.: _____

e-mail: _____

Relationship between Applicant & Owner _____

Proposed Use/Construction being applied for: _____ Zoning District: _____

SQUARE FOOTAGE for: Lot: _____ SF Main Bldg.: _____ SF Outbuildings: _____ SF

****SETBACKS for proposed construction:** Front _____ Side _____ Rear _____ Side _____

ESTIMATED COST of Construction or Alteration: \$ _____

Applicant certifies the attached **PLANS** have been **SUBMITTED** in duplicate and drawn to scale **INDICATING THE FOLLOWING:**

- Dimension and shape of lot to be built upon with the exact size and location of all buildings/structures on the lot, if any, and the **location and dimensions** of proposed building, structure or alteration **with front, sides and rear distances to property lines indicated.**
- Appropriate zoning fee according to the current fee schedule.

One copy of the plans shall be returned to the applicant after the Zoning Officer has marked such copy either approved or denied and attested to it by affixing his/her signature. The second copy shall be similarly marked and shall be retained and filed by the Zoning Officer.

The applicant hereby certifies that the statements and data contained herein and attached hereto are true and complete.

Applicant Signature _____ Date _____

REQUIRED Homeowners Signature _____ Date _____

FOR TOWNSHIP USE

Zoning Permit in accordance with the foregoing application is hereby granted, subject to the following restrictions: NONE _____

APPROVED DENIED Zoning Officer _____ Date _____

Fee _____

PAID Check No. _____